

J Series® 3030SWT Pro9™ LEDs

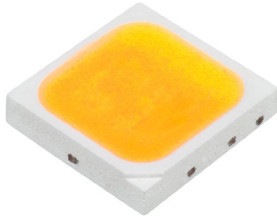

PRODUCT DESCRIPTION

J Series® LEDs provide excellent value for general and specialty lighting applications in the industry’s most common LED package sizes. The 3030S Pro9™ LEDs include high-efficacy, high-reliability 757-footprint 3030 3 V & 6 V LEDs with Samsung-compatible bins & dimensions. The Pro9 version LEDs deliver a drop-in efficacy upgrade for the 3030S LED family, with up to 28% higher efficacy for 90 CRI over standard version LEDs without sacrificing color rendering quality.

J Series 3030S Pro9™ LEDs are optimized for lighting applications that require the highest levels of efficacy, reliability and color quality.

FEATURES

- Industry-compatible size : 3.0 x 3.0 x 0.65 mm
- 3-V and 6-V configurations
- Flux and chromaticity binned at 25 °C
- 6500 K–2700 K ANSI CCTs available for 80 & 90 CRI
- RoHS and REACH compliant

PRODUCT SUMMARY

Product	Power Class	Test Temperature	Test Current	Flux Group	4000 K, 80 CRI		4000 K, 90 CRI		Maximum Current
					Minimum Flux	Maximum Flux	Minimum Flux	Maximum Flux	
JB3030S 3-V G Class Pro9	0.2 W	25 °C	65 mA	GS1	37.5 lm	40.5 lm	36.5 lm	39.5 lm	480 mA
JB3030S 3-V J Class Pro9	0.2 W	25 °C	65 mA	JS1	36.0 lm	39.0 lm	35.0 lm	38.0 lm	480 mA
JK3030S 6-V G Class Pro9	1.0 W	25 °C	150 mA	GS2	155 lm	165 lm	145 lm	155 lm	240 mA
JK3030S 6-V J Class Pro9	1.0 W	25 °C	150 mA	JS2	147 lm	157 lm	139 lm	149 lm	240 mA



J Series® Products are sold exclusively by Cree Venture LED Company Limited (“Cree Venture”), regardless of geography. Any orders for J Series Products that are submitted to Cree LED or any of its other subsidiaries will be directed to Cree Venture for acknowledgment and order fulfillment.

Cree LED / 4001 E. Hwy. 54, Suite 2000 / Durham, NC 27713 USA / +1.919.313.5330 / www.cree-led.com

TABLE OF CONTENTS

Order Code & Bin Code Formats	3
J Series® JB3030S 3-V G Class Pro9™ LEDs	4
J Series® JB3030S 3-V J Class Pro9™ LEDs	9
J Series® JK3030S 6-V G Class Pro9™ LEDs	14
J Series® JK3030S 6-V J Class Pro9™ LEDs	19
Relative Spectral Power Distribution	24
Typical Spatial Distribution.....	25
Performance Groups - Forward Voltage.....	26
Performance Groups - Chromaticity	27
Kitting.....	35
Reflow Soldering Characteristics.....	36
Notes	37
Mechanical Dimensions	39
Tape & Reel.....	40
Packaging.....	41

Order codes and bin codes for J Series 3030S Pro9 LEDs are configured in the following manner

ORDER CODE FORMAT

A B CCCC D EE - F - G HH K L MMMM - NNNN P NNN

Characters	Description	Detail
A	Series	J = J Series
B	Power Class	B = 0.2 W K = 1.0 W
CCCC	Family name	3030
D	Generation	S = S generation
EE	Color	WT = White
F	Class	G = G class J = J class
G	CRI	H = 80 CRI Minimum U = 90 CRI Minimum
HH	CCT	65 = 6500 K 57 = 5700 K 50 = 5000 K 40 = 4000 K 35 = 3500 K 30 = 3000 K 27 = 2700 K
K	Kitting	N = N kitting G = 3-step only
L	Forward Voltage	A = 3 V B = 6 V
MMMM - NNNN	Internal code	
P	Version	P = Pro9
NNN	Internal code	

BIN CODE FORMAT

J P SSSS X CC - B - WWW - FFF - VV - Y - DD P GG

Characters	Description	Detail
J	Series	J = J Series
P	Power Class	B = 0.2 W K = 1.0 W
SSSS	Family name	3030
X	Generation	S = S generation
CC	Color	WT = White
B	Internal code	
WWW	Chromaticity bin	
FFF	Flux group	
VV	Forward Voltage bin	
Y	CRI	H = 80 CRI Minimum U = 90 CRI Minimum
DD	Internal code	
P	Version	P = Pro9
GG	Internal code	

J SERIES® JB3030S 3-V G CLASS PRO9™ LEDS

CHARACTERISTICS - JB3030S 3-V G CLASS PRO9™

Characteristics	Unit	Minimum	Typical	Maximum
Thermal resistance, junction to solder point ^o	°C/W		2	
Viewing angle (FWHM)	degrees		120	
Temperature coefficient of voltage	mV/°C		-1.2	
ESD withstand voltage (HBM per Mil-Std-883L)			Class 3B	
DC forward current	mA			480
Reverse voltage	V			5
Forward voltage (@ 65 mA, 25 °C)	V	2.57	2.71	2.87
LED junction temperature	°C			125
Operating temperature	°C	-40		105

- Note:
- ◊ Thermal resistance measurement was performed per the JEDEC JESD51-14 standard. See the [Thermal Resistance Measurement application note](#) for more details.
 - Continuous reverse voltage can cause LED damage.

OPERATING LIMITS - JB3030S 3-V G CLASS PRO9™

The maximum forward current is determined by the thermal resistance between the LED junction and ambient.

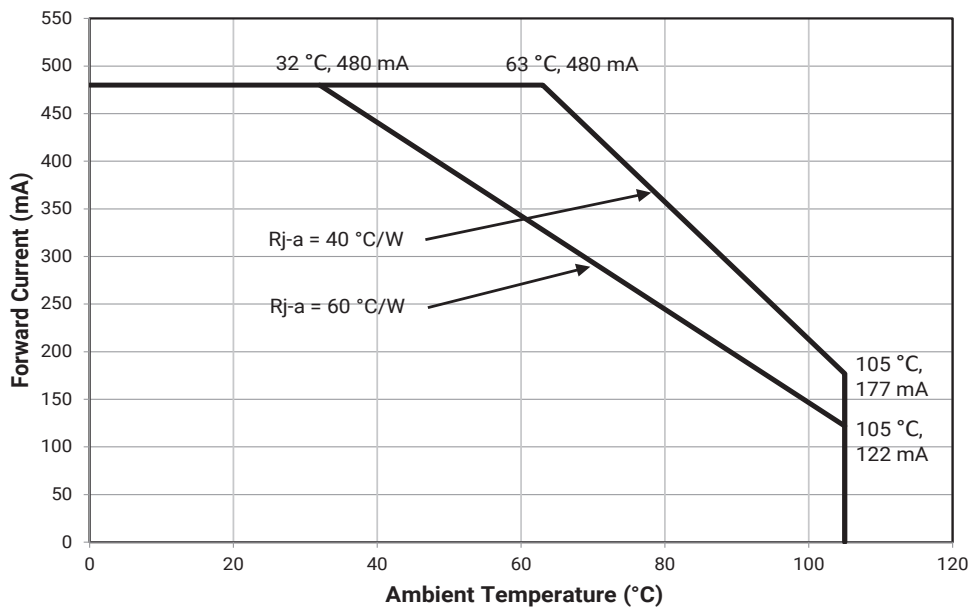

FLUX CHARACTERISTICS, ORDER CODES AND BINS - JB3030S 3-V G CLASS PRO9™ ($I_F = 65 \text{ mA}$, $T_j = 25 \text{ °C}$)

The following table provides order codes for J Series JB3030S 3-V G Class Pro9 LEDs. For a complete description of the order code nomenclature, please see the Order Code and Bin Code Formats section (page 3). For definitions of the chromaticity kits, please see the Performance Groups - Chromaticity section (page 27).

Nominal CCT	Minimum CRI	Flux Group	Minimum Flux (lm) @ 25 °C	Maximum Flux (lm) @ 25 °C	N Kitting Order Code	3-Step Order Code
6500 K	80	GS1	37	40	JB3030SWT-G-H65NA0000-SZ00P001	JB3030SWT-G-H65GA0000-SZ00P001
	90	GS1	36	39	JB3030SWT-G-U65NA0000-SZ00P001	JB3030SWT-G-U65GA0000-SZ00P001
5700 K	80	GS1	37.5	40.5	JB3030SWT-G-H57NA0000-SZ00P001	JB3030SWT-G-H57GA0000-SZ00P001
	90	GS1	36.5	39.5	JB3030SWT-G-U57NA0000-SZ00P001	JB3030SWT-G-U57GA0000-SZ00P001
5000 K	80	GS1	37.5	40.5	JB3030SWT-G-H50NA0000-SZ00P001	JB3030SWT-G-H50GA0000-SZ00P001
	90	GS1	36.5	39.5	JB3030SWT-G-U50NA0000-SZ00P001	JB3030SWT-G-U50GA0000-SZ00P001
4000 K	80	GS1	37.5	40.5	JB3030SWT-G-H40NA0000-SZ00P001	JB3030SWT-G-H40GA0000-SZ00P001
	90	GS1	36.5	39.5	JB3030SWT-G-U40NA0000-SZ00P001	JB3030SWT-G-U40GA0000-SZ00P001
3500 K	80	GS1	36.9	39.9	JB3030SWT-G-H35NA0000-SZ00P001	JB3030SWT-G-H35GA0000-SZ00P001
	90	GS1	35.9	38.9	JB3030SWT-G-U35NA0000-SZ00P001	JB3030SWT-G-U35GA0000-SZ00P001
3000 K	80	GS1	36.4	39.4	JB3030SWT-G-H30NA0000-SZ00P001	JB3030SWT-G-H30GA0000-SZ00P001
	90	GS1	35.4	38.4	JB3030SWT-G-U30NA0000-SZ00P001	JB3030SWT-G-U30GA0000-SZ00P001
2700 K	80	GS1	35.9	38.9	JB3030SWT-G-H27NA0000-SZ00P001	JB3030SWT-G-H27GA0000-SZ00P001
	90	GS1	34.8	37.8	JB3030SWT-G-U27NA0000-SZ00P001	JB3030SWT-G-U27GA0000-SZ00P001

Note:

- Cree Venture maintains a tolerance of ±7% on flux and power measurements, ±0.005 on chromaticity (CCx, CCy) measurements and ±2 on CRI measurements. See the Measurements section (page 37).

RELATIVE LUMINOUS FLUX VS. CURRENT - JB3030S 3-V G CLASS PRO9™

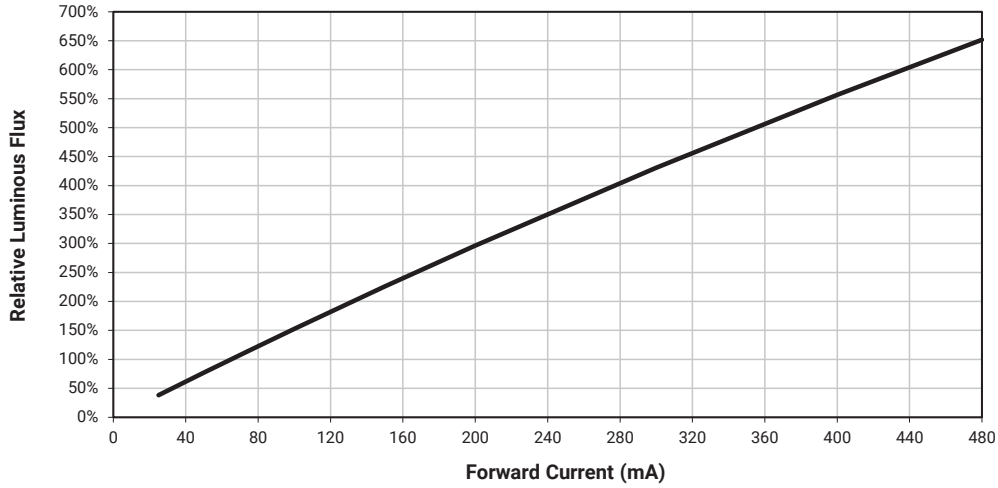

ELECTRICAL CHARACTERISTICS - JB3030S 3-V G CLASS PRO9™

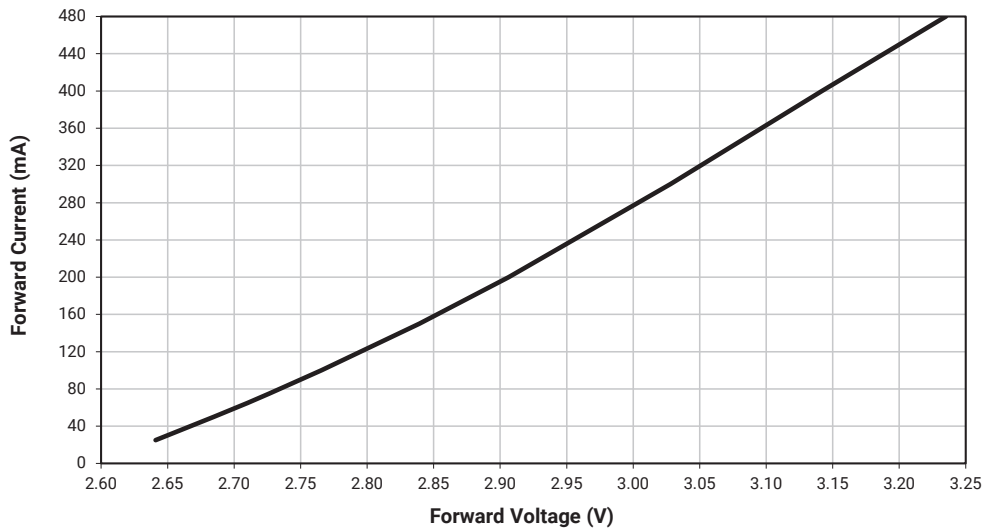

RELATIVE CHROMATICITY VS. CURRENT - JB3030S 3-V G CLASS PRO9™

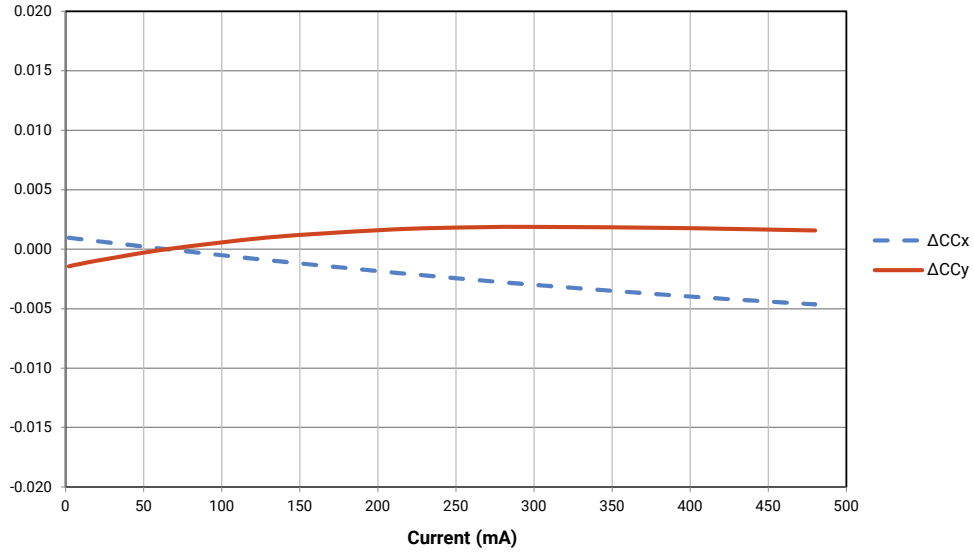

RELATIVE CHROMATICITY VS. TEMPERATURE - JB3030S 3-V G CLASS PRO9™

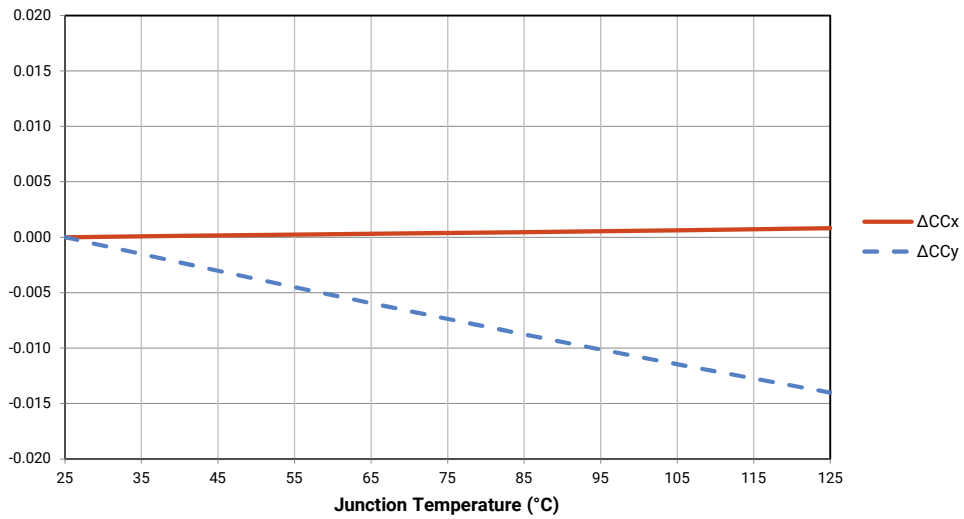

- Relative Chromaticity versus Current and Temperature are shown for reference only.

RELATIVE LUMINOUS FLUX VS. JUNCTION TEMPERATURE - JB3030S 3-V G CLASS PRO9™

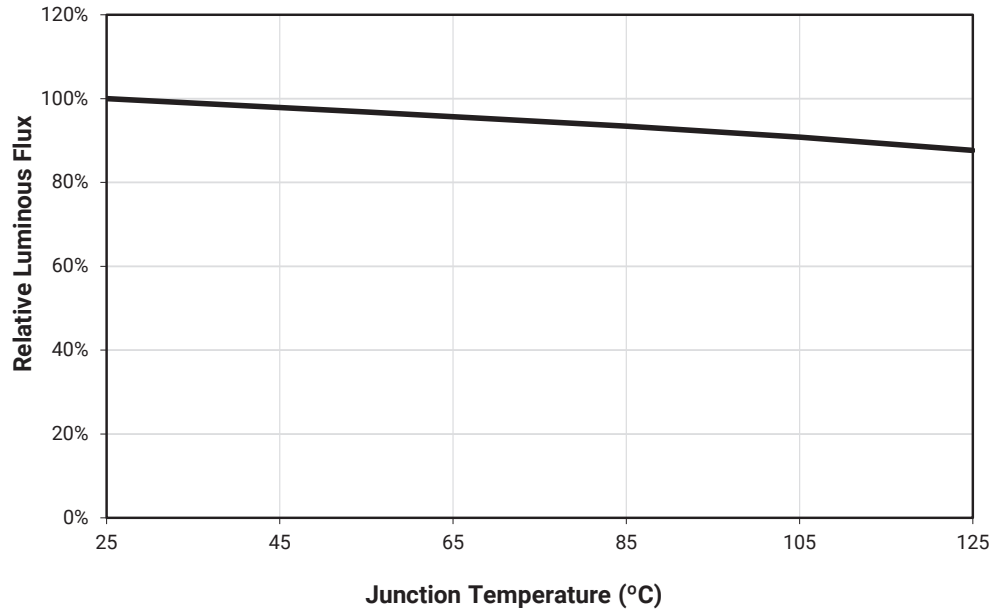

J SERIES® JB3030S 3-V J CLASS PRO9™ LEDS

CHARACTERISTICS - JB3030S 3-V J CLASS PRO9™

Characteristics	Unit	Minimum	Typical	Maximum
Thermal resistance, junction to solder point ⁹	°C/W		4	
Viewing angle (FWHM)	degrees		120	
ESD withstand voltage (HBM per MIL-STD-883L)			Class 3B	
DC forward current	mA			480
Reverse voltage	V			5
Forward voltage (@ 65 mA, 25 °C)	V	2.59	2.74	2.89
LED junction temperature	°C			125
Operating temperature	°C	-40		105

- Note
- ◇ Thermal resistance measurement was performed per the JEDEC JESD51-14 standard. See the [Thermal Resistance Measurement application note](#) for more details.
 - Continuous reverse voltage can cause LED damage.

OPERATING LIMITS - JB3030S 3-V J CLASS PRO9™

The maximum forward current is determined by the thermal resistance between the LED junction and ambient.

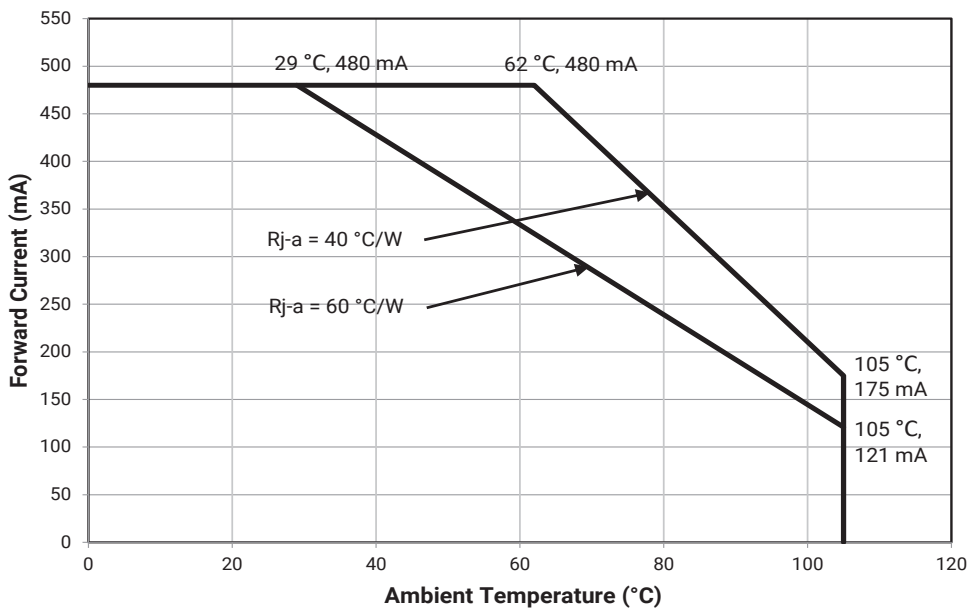

FLUX CHARACTERISTICS, ORDER CODES AND BINS - JB3030S 3-V J CLASS PRO9™ ($I_F = 65 \text{ mA}$, $T_j = 25 \text{ °C}$)

The following table provides order codes for J Series JB3030S 3-V J Class Pro9 LEDs. For a complete description of the order code nomenclature, please see the Order Code and Bin Code Formats section (page 3). For definitions of the chromaticity kits, please see the Performance Groups - Chromaticity section (page 27).

Nominal CCT	Minimum CRI	Flux Group	Minimum Flux (lm) @ 25 °C	Maximum Flux (lm) @ 25 °C	N Kitting Order Code	3-Step Order Code
6500 K	80	JS1	35.5	38.5	JB3030SWT-J-H65NA0000-SZ00P001	JB3030SWT-J-H65GA0000-SZ00P001
	90	JS1	34.5	37.5	JB3030SWT-J-U65NA0000-SZ00P001	JB3030SWT-J-U65GA0000-SZ00P001
5700 K	80	JS1	36	39	JB3030SWT-J-H57NA0000-SZ00P001	JB3030SWT-J-H57GA0000-SZ00P001
	90	JS1	35	38	JB3030SWT-J-U57NA0000-SZ00P001	JB3030SWT-J-U57GA0000-SZ00P001
5000 K	80	JS1	36	39	JB3030SWT-J-H50NA0000-SZ00P001	JB3030SWT-J-H50GA0000-SZ00P001
	90	JS1	35	38	JB3030SWT-J-U50NA0000-SZ00P001	JB3030SWT-J-U50GA0000-SZ00P001
4000 K	80	JS1	36	39	JB3030SWT-J-H40NA0000-SZ00P001	JB3030SWT-J-H40GA0000-SZ00P001
	90	JS1	35	38	JB3030SWT-J-U40NA0000-SZ00P001	JB3030SWT-J-U40GA0000-SZ00P001
3500 K	80	JS1	35.4	38.4	JB3030SWT-J-H35NA0000-SZ00P001	JB3030SWT-J-H35GA0000-SZ00P001
	90	JS1	34.3	37.3	JB3030SWT-J-U35NA0000-SZ00P001	JB3030SWT-J-U35GA0000-SZ00P001
3000 K	80	JS1	34.8	37.8	JB3030SWT-J-H30NA0000-SZ00P001	JB3030SWT-J-H30GA0000-SZ00P001
	90	JS1	33.8	36.8	JB3030SWT-J-U30NA0000-SZ00P001	JB3030SWT-J-U30GA0000-SZ00P001
2700 K	80	JS1	34.3	37.3	JB3030SWT-J-H27NA0000-SZ00P001	JB3030SWT-J-H27GA0000-SZ00P001
	90	JS1	33.3	36.3	JB3030SWT-J-U27NA0000-SZ00P001	JB3030SWT-J-U27GA0000-SZ00P001

Note:

- Cree Venture maintains a tolerance of ±7% on flux and power measurements, ±0.005 on chromaticity (CCx, CCy) measurements and ±2 on CRI measurements. See the Measurements section (page 37).

RELATIVE LUMINOUS FLUX VS. CURRENT - JB3030S 3-V J CLASS PRO9™

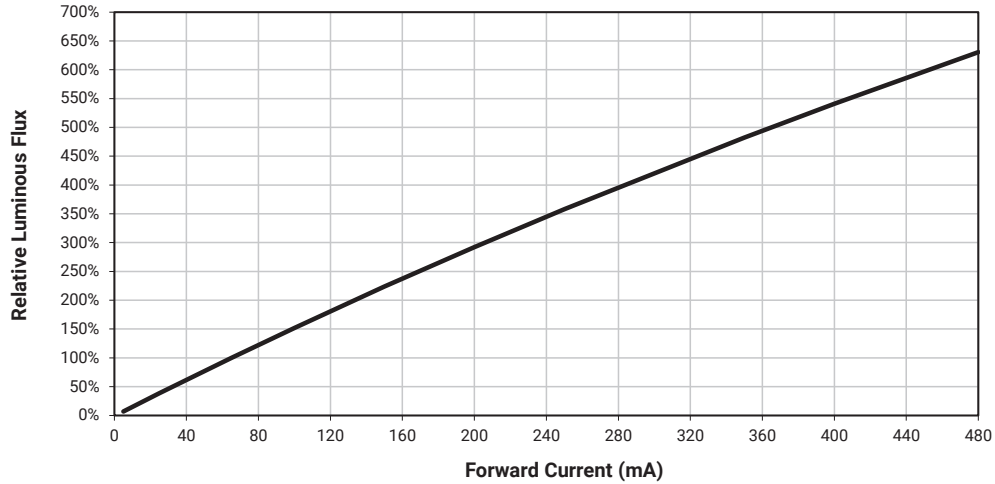

ELECTRICAL CHARACTERISTICS - JB3030S 3-V J CLASS PRO9™

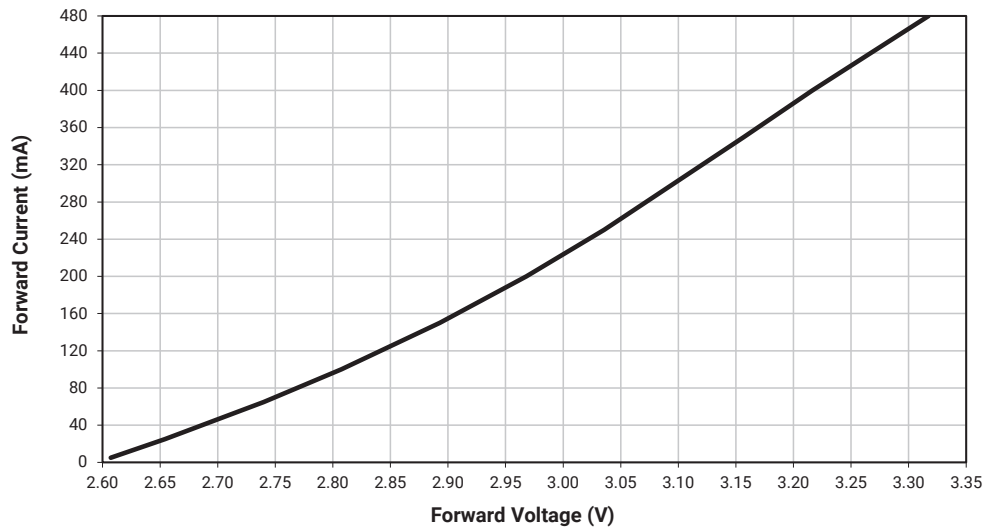

RELATIVE CHROMATICITY VS. CURRENT - JB3030S 3-V J CLASS PRO9™

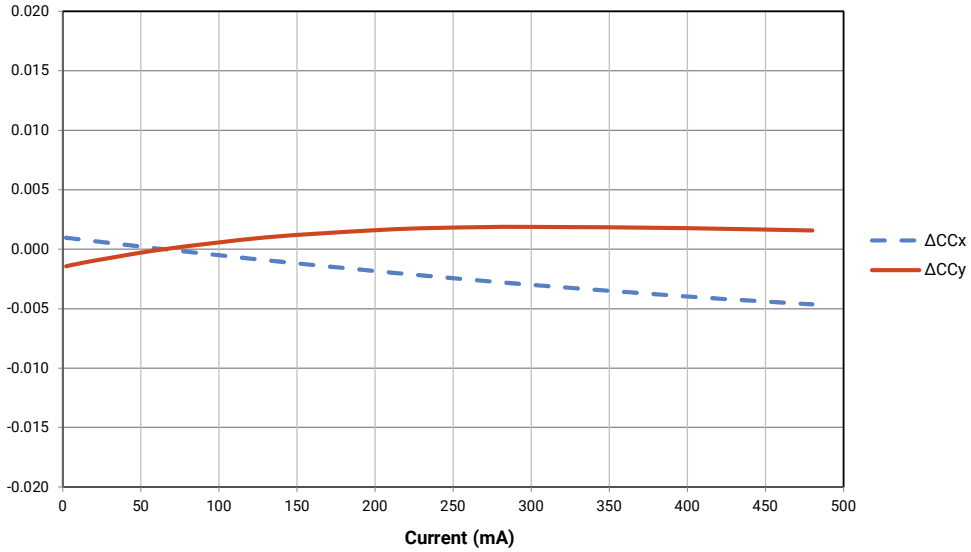

RELATIVE CHROMATICITY VS. JUNCTION TEMPERATURE - JB3030S 3-V J CLASS PRO9™

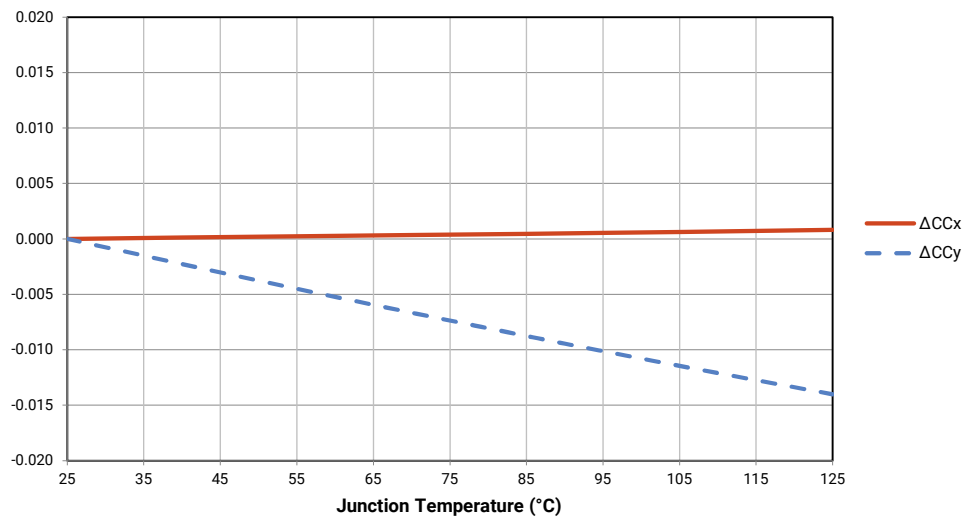

- Relative Chromaticity versus Current and Temperature are shown for reference only.

RELATIVE FLUX VS. JUNCTION TEMPERATURE - JB3030S 3-V J CLASS PRO9™

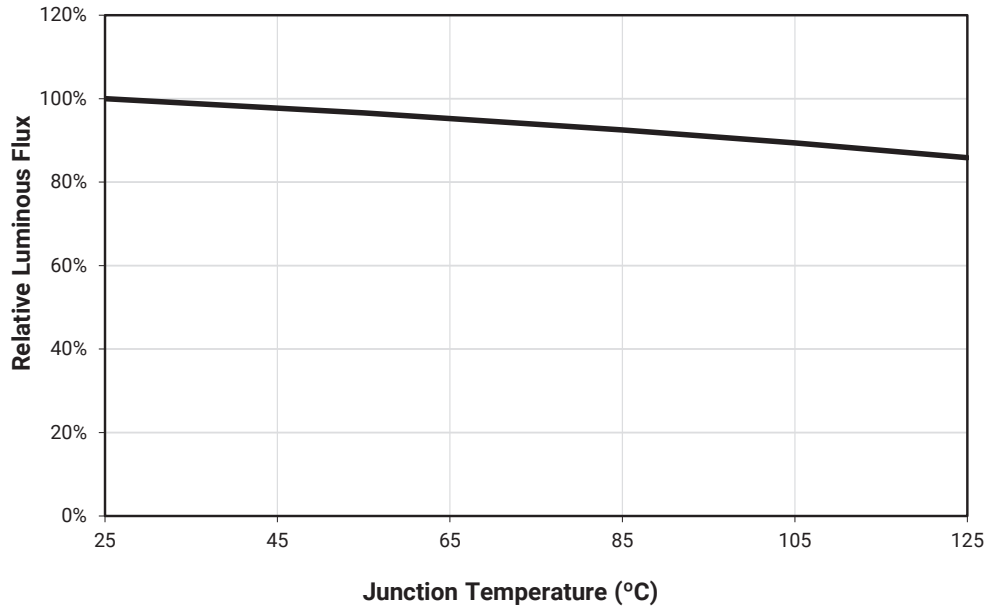

J SERIES® JK3030S 6-V G CLASS PRO9™ LEDS

CHARACTERISTICS - JK3030S 6-V G CLASS PRO9™

Characteristics	Unit	Minimum	Typical	Maximum
Thermal resistance, junction to solder point ^o	°C/W		5	
Viewing angle (FWHM)	degrees		120	
Temperature coefficient of voltage	mV/°C		-2.1	
ESD withstand voltage (HBM per Mil-Std-883L)			Class 3B	
DC forward current	mA			240
Reverse voltage	V			5
Forward voltage (@ 150 mA, 25 °C)	V	5.9	6.13	6.4
LED junction temperature	°C			125
Operating temperature	°C	-40		105

- Note:
- ◇ Thermal resistance measurement was performed per the JEDEC JESD51-14 standard. See the [Thermal Resistance Measurement application note](#) for more details.
 - Continuous reverse voltage can cause LED damage.

OPERATING LIMITS - JK3030S 6-V G CLASS PRO9™

The maximum forward current is determined by the thermal resistance between the LED junction and ambient.

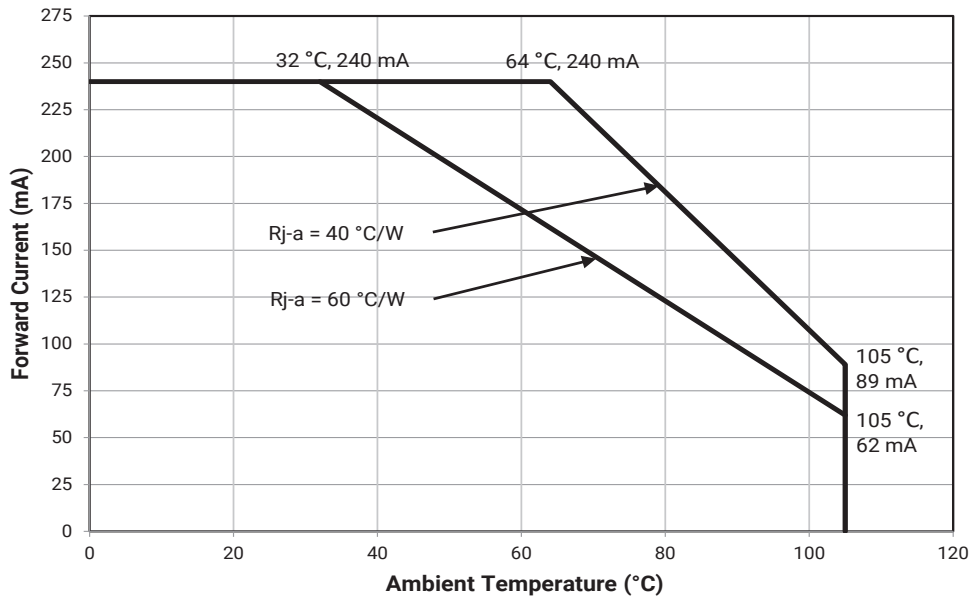

FLUX CHARACTERISTICS, ORDER CODES AND BINS - JK3030S 6-V G CLASS PRO9™ ($I_F = 150 \text{ mA}$, $T_j = 25 \text{ °C}$)

The following table provides order codes for J Series JK3030S 6-V J Class Pro9 LEDs. For a complete description of the order code nomenclature, please see the Order Code and Bin Code Formats section (page 3). For definitions of the chromaticity kits, please see the Performance Groups - Chromaticity section (page 27).

Nominal CCT	Minimum CRI	Flux Group	Minimum Flux (lm) @ 25 °C	Maximum Flux (lm) @ 25 °C	N Kitting Order Code	3-Step Order Code
6500 K	80	GS2	152	162	JK3030SWT-G-H65NB0000-SZ00P001	JK3030SWT-G-H65GB0000-SZ00P001
	90	GS2	143	153	JK3030SWT-G-U65NB0000-SZ00P001	JK3030SWT-G-U65GB0000-SZ00P001
5700 K	80	GS2	155	165	JK3030SWT-G-H57NB0000-SZ00P001	JK3030SWT-G-H57GB0000-SZ00P001
	90	GS2	145	155	JK3030SWT-G-U57NB0000-SZ00P001	JK3030SWT-G-U57GB0000-SZ00P001
5000 K	80	GS2	155	165	JK3030SWT-G-H50NB0000-SZ00P001	JK3030SWT-G-H50GB0000-SZ00P001
	90	GS2	145	155	JK3030SWT-G-U50NB0000-SZ00P001	JK3030SWT-G-U50GB0000-SZ00P001
4000 K	80	GS2	155	165	JK3030SWT-G-H40NB0000-SZ00P001	JK3030SWT-G-H40GB0000-SZ00P001
	90	GS2	145	155	JK3030SWT-G-U40NB0000-SZ00P001	JK3030SWT-G-U40GB0000-SZ00P001
3500 K	80	GS2	150	160	JK3030SWT-G-H35NB0000-SZ00P001	JK3030SWT-G-H35GB0000-SZ00P001
	90	GS2	142	152	JK3030SWT-G-U35NB0000-SZ00P001	JK3030SWT-G-U35GB0000-SZ00P001
3000 K	80	GS2	148	158	JK3030SWT-G-H30NB0000-SZ00P001	JK3030SWT-G-H30GB0000-SZ00P001
	90	GS2	136	146	JK3030SWT-G-U30NB0000-SZ00P001	JK3030SWT-G-U30GB0000-SZ00P001
2700 K	80	GS2	145	155	JK3030SWT-G-H27NB0000-SZ00P001	JK3030SWT-G-H27GB0000-SZ00P001
	90	GS2	134	144	JK3030SWT-G-U27NB0000-SZ00P001	JK3030SWT-G-U27GB0000-SZ00P001

Note:

- Cree Venture maintains a tolerance of ±7% on flux and power measurements, ±0.005 on chromaticity (CCx, CCy) measurements and ±2 on CRI measurements. See the Measurements section (page 37).

RELATIVE LUMINOUS FLUX VS. CURRENT - JK3030S 6-V G CLASS PRO9™

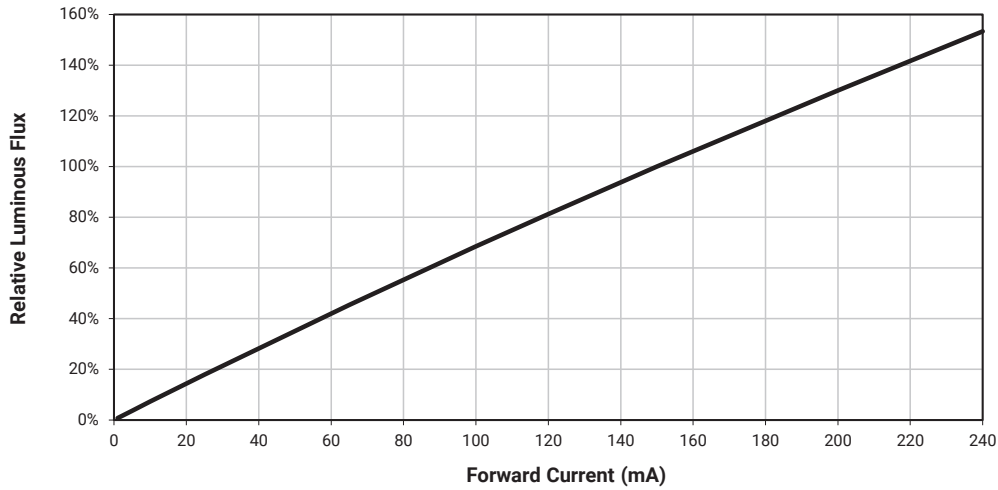

ELECTRICAL CHARACTERISTICS - JK3030S 6-V G CLASS PRO9™

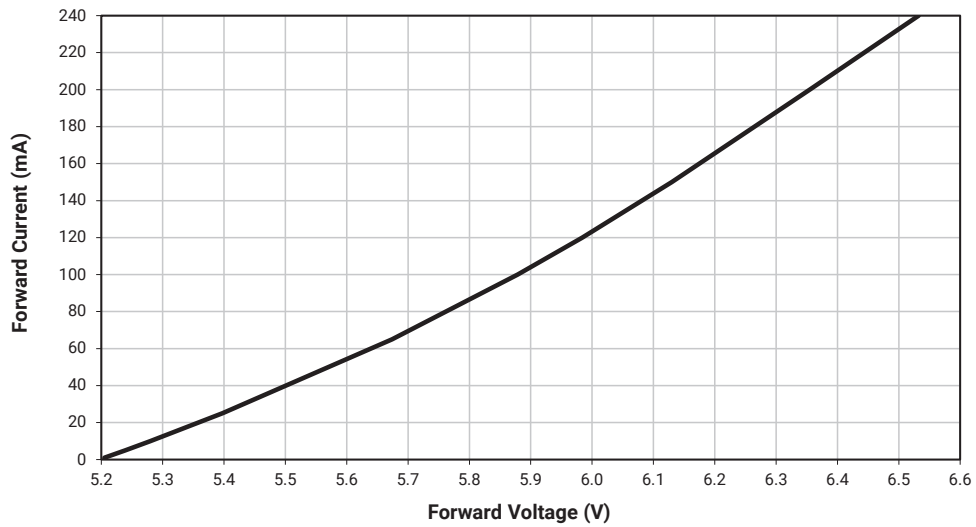

RELATIVE CHROMATICITY VS. CURRENT - JK3030S 6-V G CLASS PRO9™

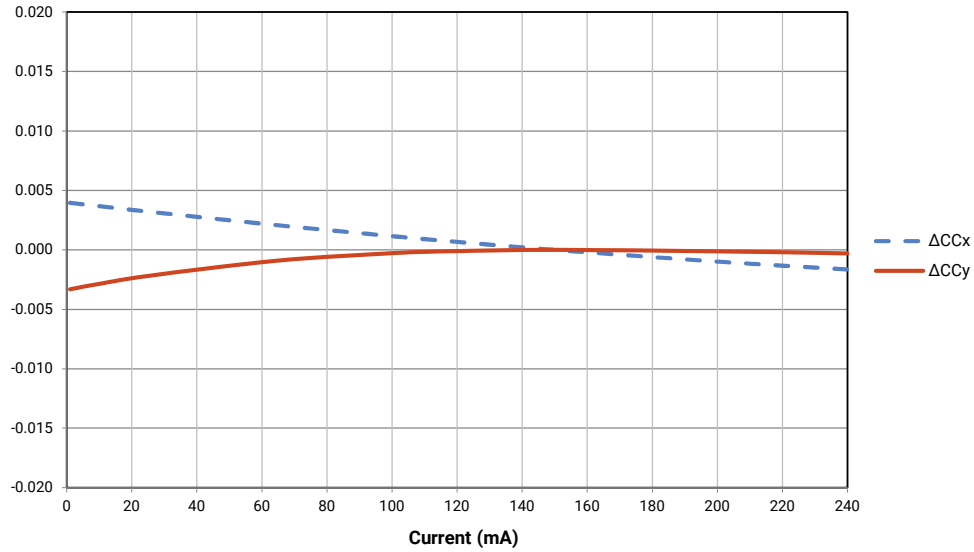

RELATIVE CHROMATICITY VS. TEMPERATURE - JK3030S 6-V G CLASS PRO9™

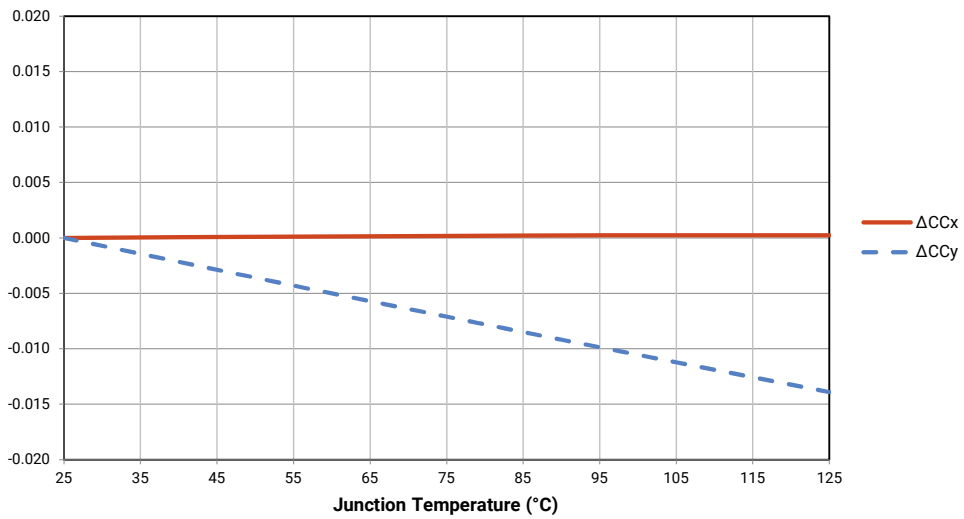

- Relative Chromaticity versus Current and Temperature are shown for reference only.

RELATIVE LUMINOUS FLUX VS. JUNCTION TEMPERATURE - JK3030S 6-V G CLASS PRO9™

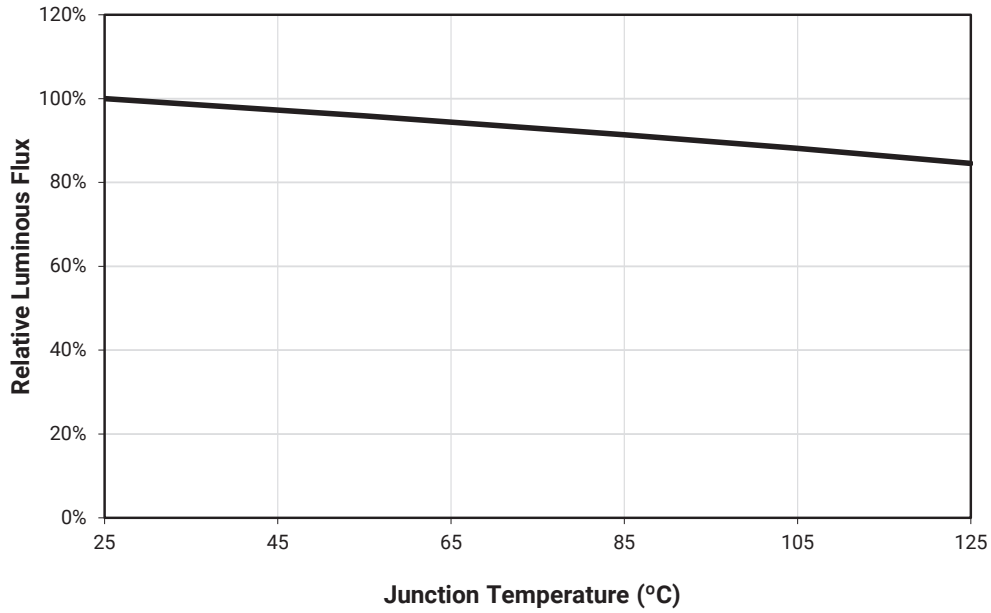

J SERIES® JK3030S 6-V J CLASS PRO9™ LEDS

CHARACTERISTICS - JK3030S 6-V J CLASS PRO9™

Characteristics	Unit	Minimum	Typical	Maximum
Thermal resistance, junction to solder point ⁹	°C/W		4	
Viewing angle (FWHM)	degrees		120	
ESD withstand voltage (HBM per MIL-STD-883L)			Class 3B	
DC forward current	mA			240
Reverse voltage	V			5
Forward voltage (@ 150 mA, 25 °C)	V	5.9	6.18	6.4
LED junction temperature	°C			125
Operating temperature	°C	-40		105

- Note
- ◇ Thermal resistance measurement was performed per the JEDEC JESD51-14 standard. See the [Thermal Resistance Measurement application note](#) for more details.
 - Continuous reverse voltage can cause LED damage.

OPERATING LIMITS - JK3030S 6-V J CLASS PRO9™

The maximum forward current is determined by the thermal resistance between the LED junction and ambient.

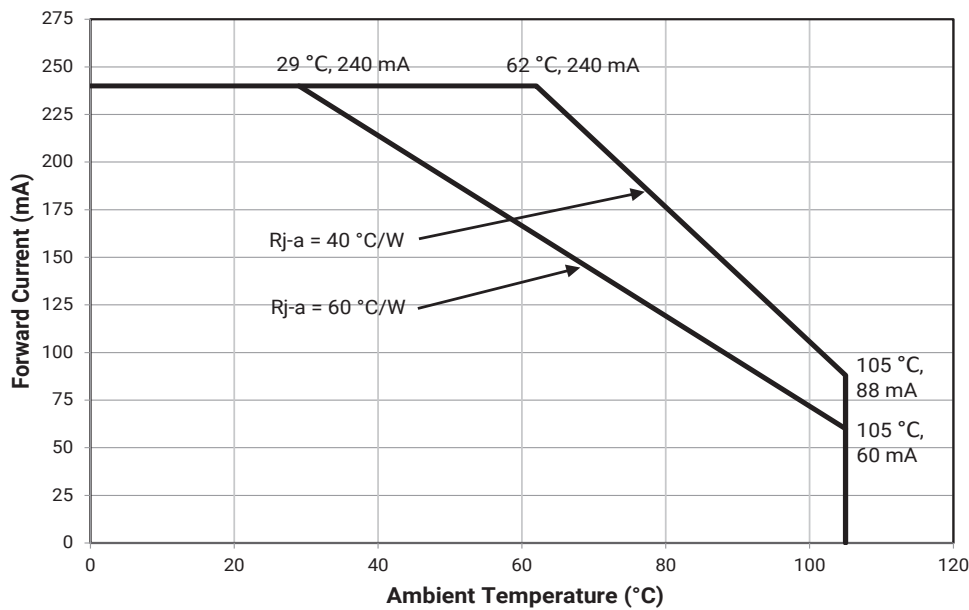

FLUX CHARACTERISTICS, ORDER CODES AND BINS - JK3030S 6-V J CLASS PRO9™ ($I_F = 150 \text{ mA}$, $T_j = 25 \text{ °C}$)

The following table provides order codes for J Series JK3030S 6-V J Class Pro9 LEDs. For a complete description of the order code nomenclature, please see the Order Code and Bin Code Formats section (page 3). For definitions of the chromaticity Kits, please see the Performance Groups - Chromaticity section (page 27).

Nominal CCT	Minimum CRI	Flux Group	Minimum Flux (lm) @ 25 °C	Maximum Flux (lm) @ 25 °C	N Kitting Order Code	3-Step Order Code
6500 K	80	JS2	146	156	JK3030SWT-J-H65NB0000-SZ00P001	JK3030SWT-J-H65GB0000-SZ00P001
	90	JS2	138	148	JK3030SWT-J-U65NB0000-SZ00P001	JK3030SWT-J-U65GB0000-SZ00P001
5700 K	80	JS2	147	157	JK3030SWT-J-H57NB0000-SZ00P001	JK3030SWT-J-H57GB0000-SZ00P001
	90	JS2	139	149	JK3030SWT-J-U57NB0000-SZ00P001	JK3030SWT-J-U57GB0000-SZ00P001
5000 K	80	JS2	147	157	JK3030SWT-J-H50NB0000-SZ00P001	JK3030SWT-J-H50GB0000-SZ00P001
	90	JS2	139	149	JK3030SWT-J-U50NB0000-SZ00P001	JK3030SWT-J-U50GB0000-SZ00P001
4000 K	80	JS2	147	157	JK3030SWT-J-H40NB0000-SZ00P001	JK3030SWT-J-H40GB0000-SZ00P001
	90	JS2	139	149	JK3030SWT-J-U40NB0000-SZ00P001	JK3030SWT-J-U40GB0000-SZ00P001
3500 K	80	JS2	145	155	JK3030SWT-J-H35NB0000-SZ00P001	JK3030SWT-J-H35GB0000-SZ00P001
	90	JS2	137	147	JK3030SWT-J-U35NB0000-SZ00P001	JK3030SWT-J-U35GB0000-SZ00P001
3000 K	80	JS2	141	151	JK3030SWT-J-H30NB0000-SZ00P001	JK3030SWT-J-H30GB0000-SZ00P001
	90	JS2	128	138	JK3030SWT-J-U30NB0000-SZ00P001	JK3030SWT-J-U30GB0000-SZ00P001
2700 K	80	JS2	140	150	JK3030SWT-J-H27NB0000-SZ00P001	JK3030SWT-J-H27GB0000-SZ00P001
	90	JS2	127	137	JK3030SWT-J-U27NB0000-SZ00P001	JK3030SWT-J-U27GB0000-SZ00P001

- Note:**
- Cree Venture maintains a tolerance of $\pm 7\%$ on flux and power measurements, ± 0.005 on chromaticity (CCx, CCy) measurements and ± 2 on CRI measurements. See the Measurements section (page 37).

RELATIVE LUMINOUS FLUX VS. CURRENT - JK3030S 6-V J CLASS PRO9™

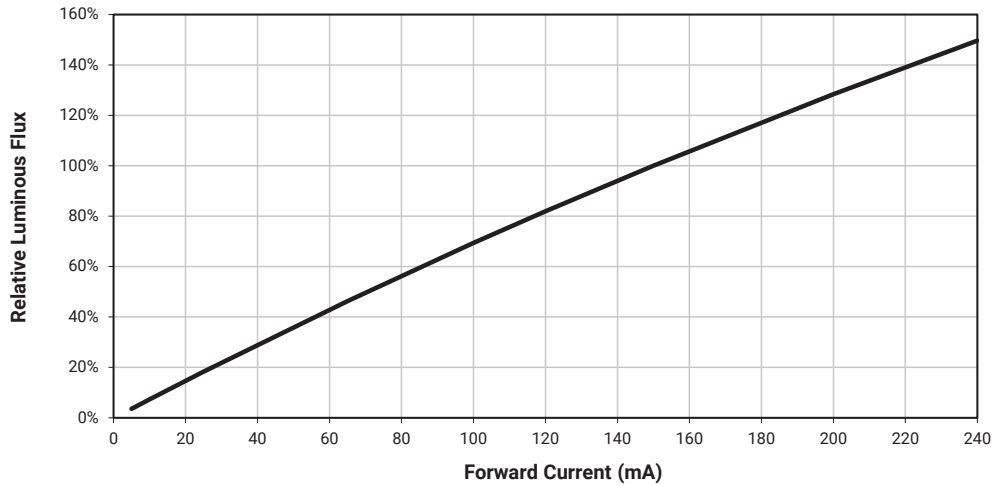

ELECTRICAL CHARACTERISTICS - JK3030S 6-V J CLASS PRO9™

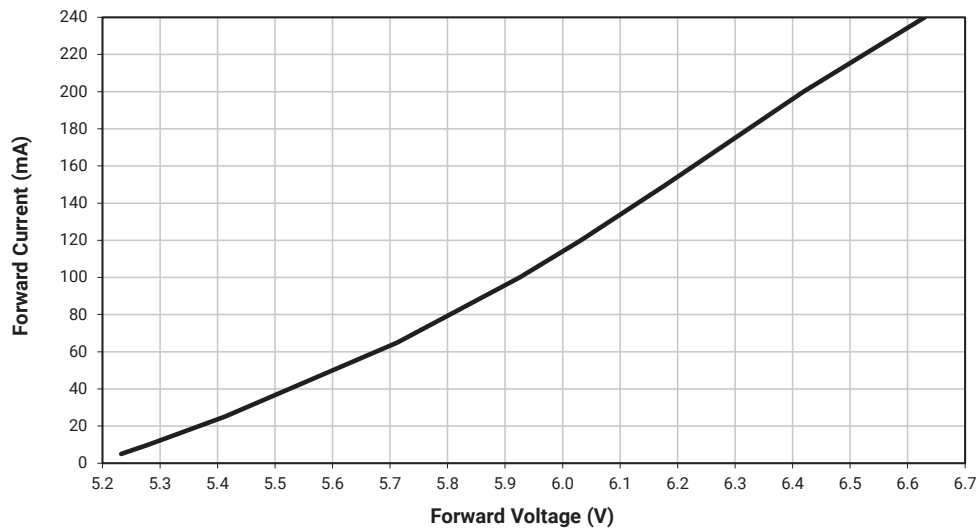

RELATIVE CHROMATICITY VS. CURRENT - JK3030S 6-V J CLASS PRO9™

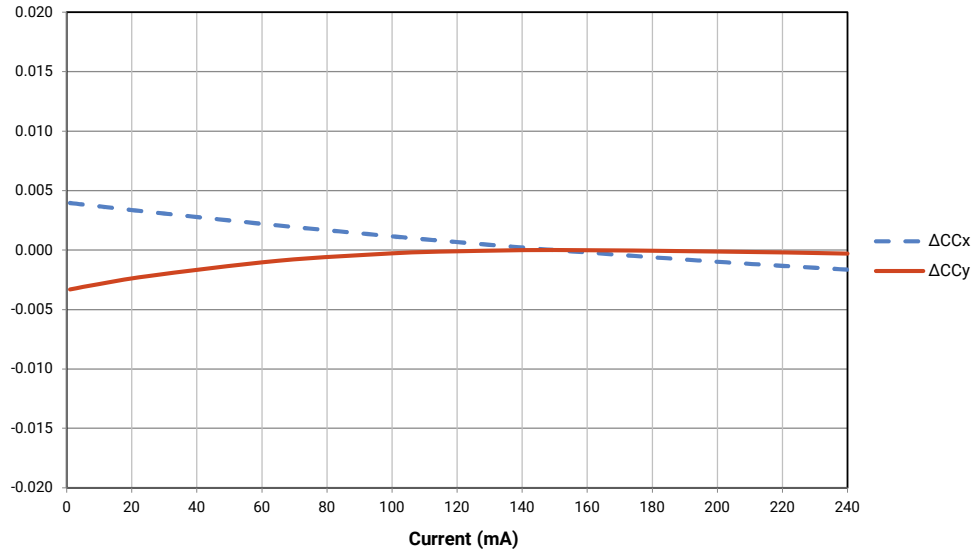

RELATIVE CHROMATICITY VS. JUNCTION TEMPERATURE - JK3030S 6-V J CLASS PRO9™

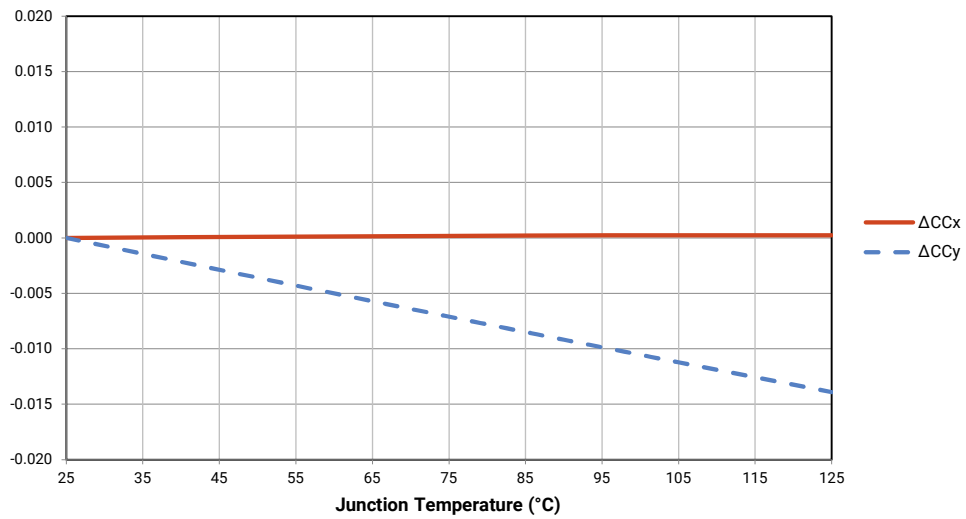

- Relative Chromaticity versus Current and Temperature are shown for reference only.

RELATIVE FLUX VS. JUNCTION TEMPERATURE - JK3030S 6-V J CLASS PRO9™

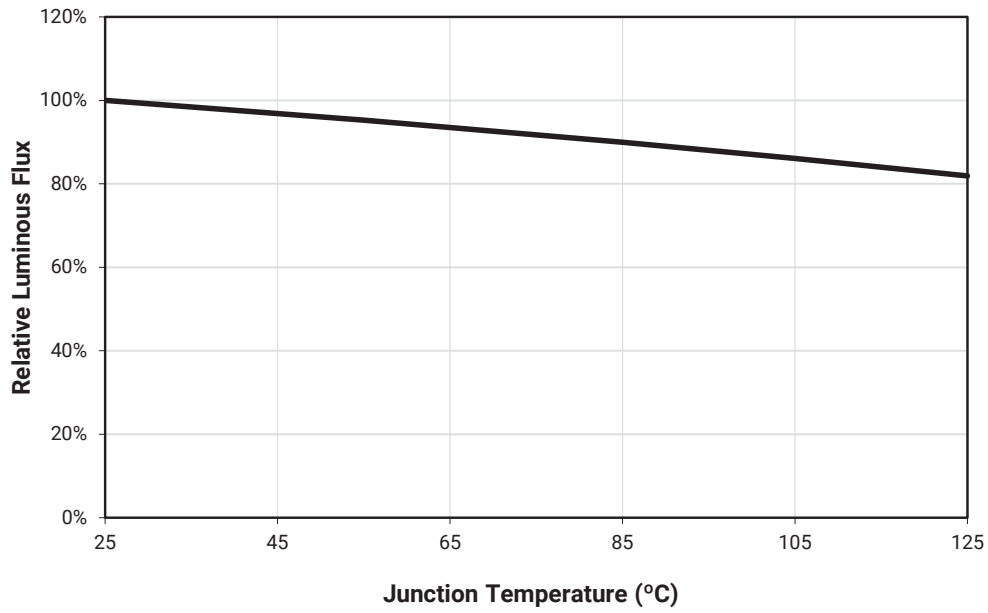

RELATIVE SPECTRAL POWER DISTRIBUTION

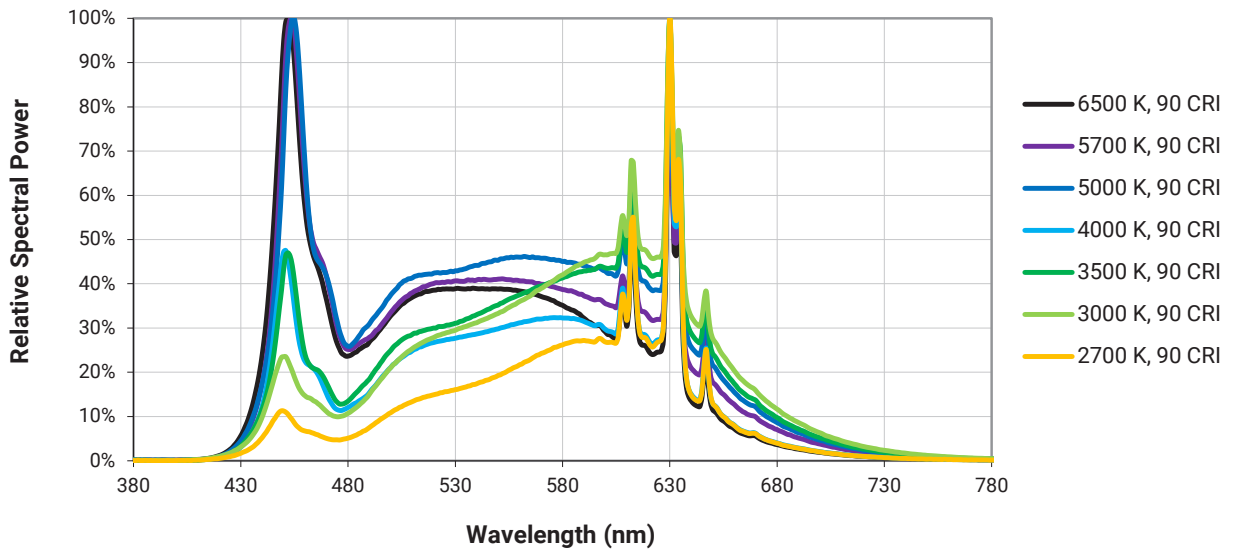
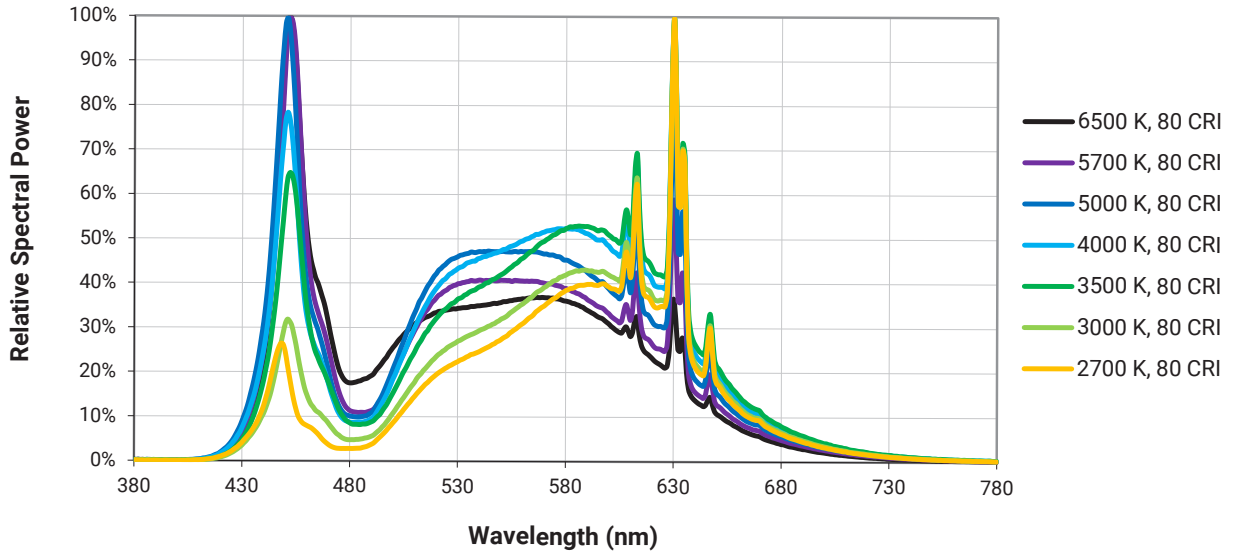

TYPICAL SPATIAL DISTRIBUTION

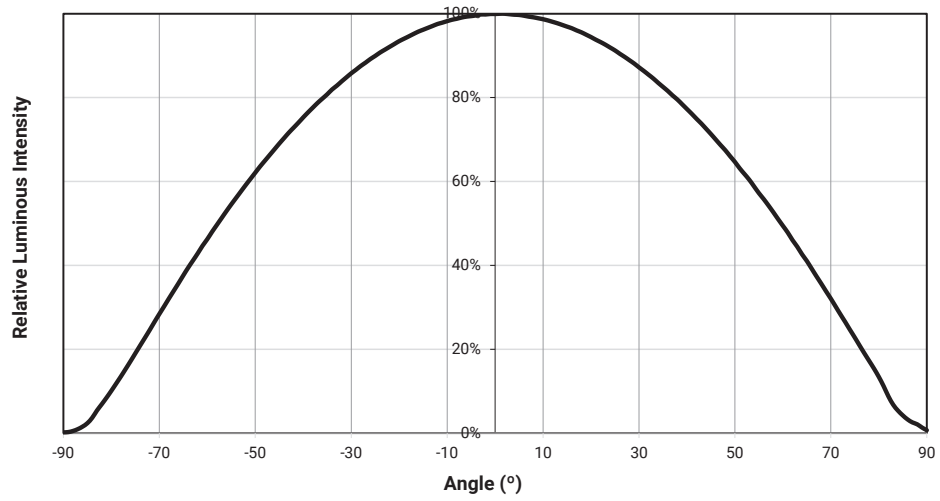

PERFORMANCE GROUPS - FORWARD VOLTAGE ($T_j = 25\text{ }^\circ\text{C}$)

J Series 3030S Pro9 LEDs are tested for forward voltage and placed into one of the following voltage bins.

The following voltage bins are indicated in the Forward Voltage Bin field in the bin code for JB3030S 3-V G Class Pro9 LEDs.

Voltage Bin	Minimum Forward Voltage (V)	Maximum Forward Voltage (V)
AC	2.57	2.67
AD	2.67	2.77
AE	2.77	2.87

The following voltage bins are indicated in the Forward Voltage Bin field in the bin code for JB3030S 3-V J Class Pro9 LEDs.

Voltage Bin	Minimum Forward Voltage (V)	Maximum Forward Voltage (V)
AC	2.59	2.69
AD	2.69	2.79
AE	2.79	2.89

The following voltage bins are indicated in the Forward Voltage Bin field in the bin code for JK3030S 6-V G Class Pro9 and JK3030S 6-V J Class Pro9 LEDs.

Voltage Bin	Minimum Forward Voltage (V)	Maximum Forward Voltage (V)
BB	5.9	6.0
BC	6.0	6.1
BD	6.1	6.2
BE	6.2	6.3
BF	6.3	6.4

PERFORMANCE GROUPS - CHROMATICITY ($T_j = 25\text{ }^\circ\text{C}$)

J Series 3030S Pro9 LEDs are tested for chromaticity and placed into one of the regions defined by the following bounding coordinates.

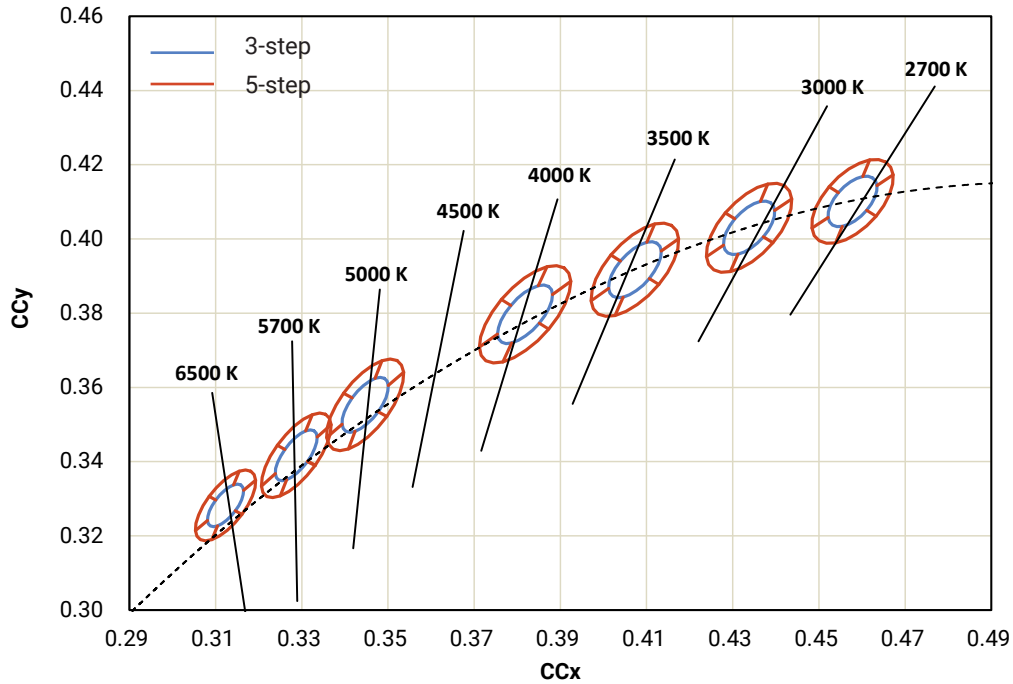

PERFORMANCE GROUPS - CHROMATICITY ($T_j = 25\text{ }^\circ\text{C}$) - CONTINUED

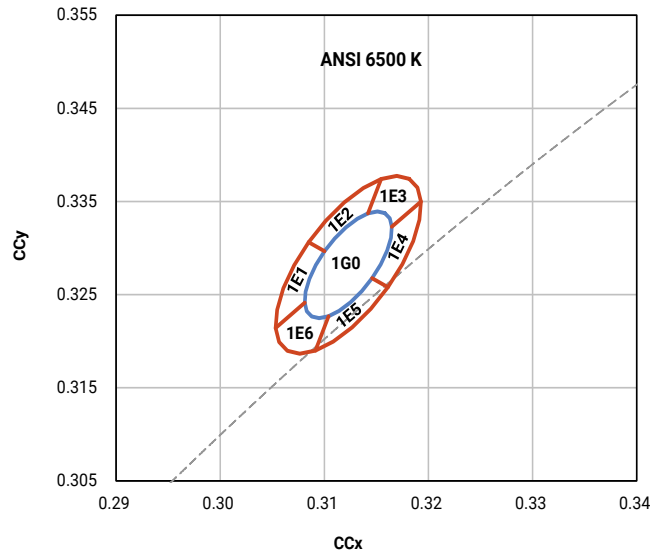

CCT	MacAdam Ellipse	Included Bins	Center Point		Major Axis	Minor Axis	Rotation Angle (°)
			x	y	a	b	
6500 K	3-step	1G0	0.3123	0.3282	0.0067	0.0029	58.6
	5-step	1G0, 1E1, 1E2, 1E3, 1E4, 1E5, 1E6	0.3123	0.3282	0.0112	0.0048	58.6

PERFORMANCE GROUPS - CHROMATICITY ($T_j = 25\text{ °C}$) - CONTINUED

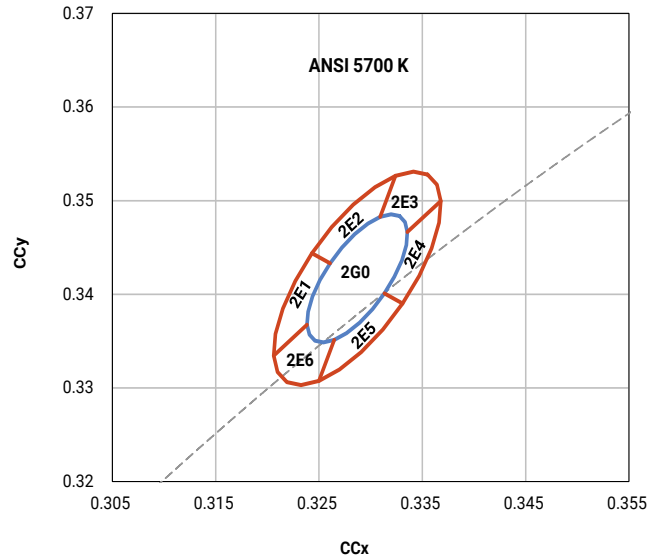

CCT	MacAdam Ellipse	Included Bins	Center Point		Major Axis	Minor Axis	Rotation Angle (°)
			x	y	a	b	
5700 K	3-step	2G0	0.3287	0.3417	0.0075	0.0032	59.1
	5-step	2G0, 2E1, 2E2, 2E3, 2E4, 2E5, 2E6	0.3287	0.3417	0.0125	0.0053	59.1

PERFORMANCE GROUPS - CHROMATICITY ($T_j = 25\text{ °C}$) - CONTINUED

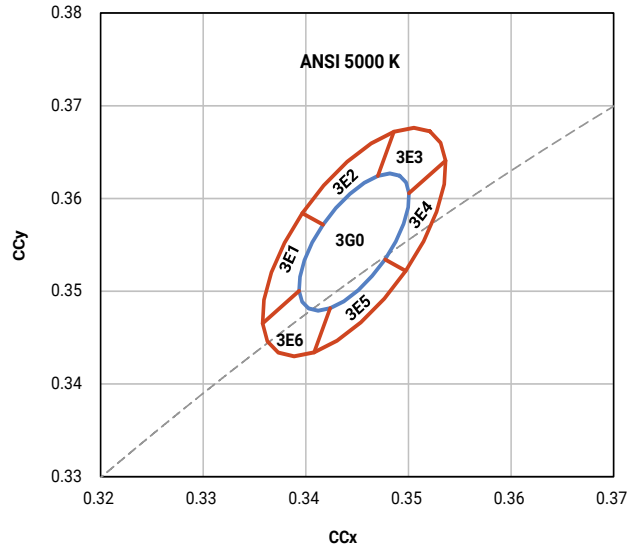

CCT	MacAdam Ellipse	Included Bins	Center Point		Major Axis	Minor Axis	Rotation Angle (°)
			x	y	a	b	
5000 K	3-step	3G0	0.3447	0.3553	0.0082	0.0035	59.6
	5-step	3G0, 3E1, 3E2, 3E3, 3E4, 3E5, 3E6	0.3447	0.3553	0.0137	0.0059	59.6

PERFORMANCE GROUPS - CHROMATICITY ($T_j = 25\text{ °C}$) - CONTINUED

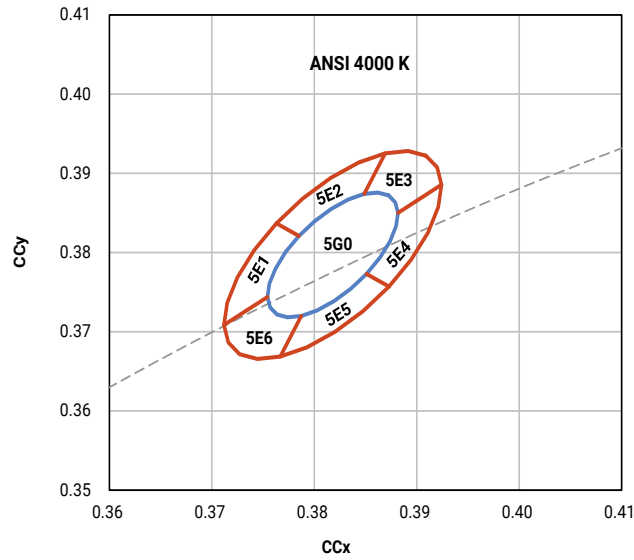

CCT	MacAdam Ellipse	Included Bins	Center Point		Major Axis	Minor Axis	Rotation Angle (°)
			x	y	a	b	
4000 K	3-step	5G0	0.3818	0.3797	0.0094	0.0040	53.7
	5-step	5G0, 5E1, 5E2, 5E3, 5E4, 5E5, 5E6	0.3818	0.3797	0.0157	0.0067	53.7

PERFORMANCE GROUPS - CHROMATICITY ($T_j = 25\text{ °C}$) - CONTINUED

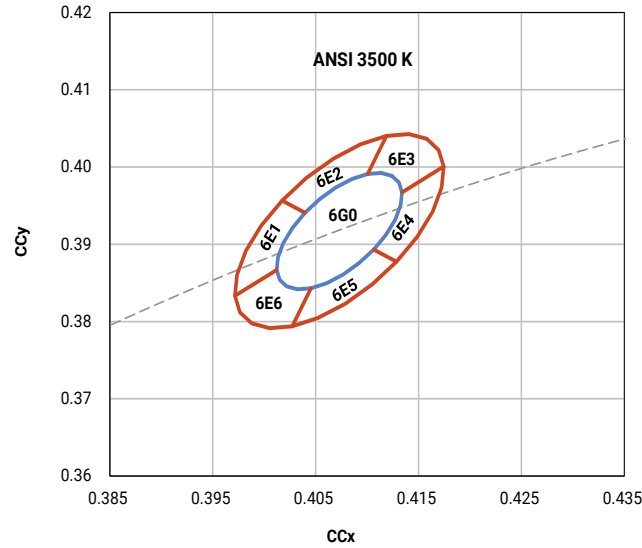

CCT	MacAdam Ellipse	Included Bins	Center Point		Major Axis	Minor Axis	Rotation Angle (°)
			x	y	a	b	
3500 K	3-step	6G0	0.4073	0.3917	0.0093	0.0041	54.0
	5-step	6G0, 6E1, 6E2, 6E3, 6E4, 6E5, 6E6	0.4073	0.3917	0.0155	0.0068	54.0

PERFORMANCE GROUPS - CHROMATICITY ($T_j = 25\text{ }^\circ\text{C}$) - CONTINUED

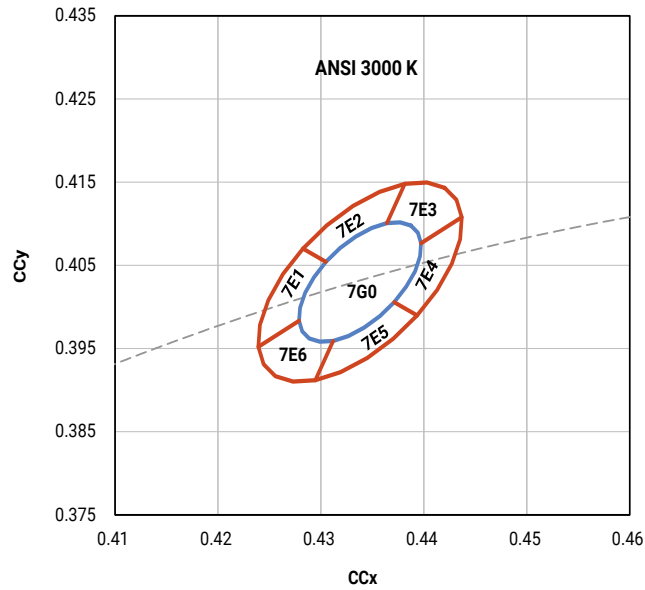

CCT	MacAdam Ellipse	Included Bins	Center Point		Major Axis	Minor Axis	Rotation Angle (°)
			x	y	a	b	
3000 K	3-step	7G0	0.4338	0.4030	0.0083	0.0041	53.2
	5-step	7G0, 7E1, 7E2, 7E3, 7E4, 7E5, 7E6	0.4338	0.4030	0.0138	0.0068	53.2

PERFORMANCE GROUPS - CHROMATICITY ($T_j = 25\text{ °C}$) - CONTINUED

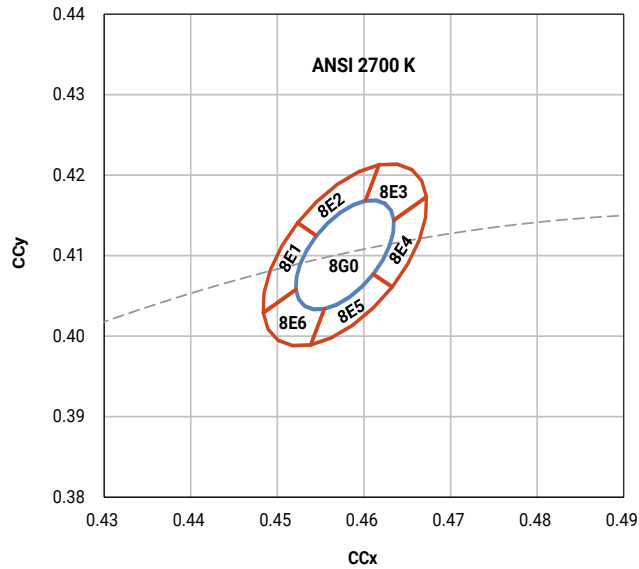

CCT	MacAdam Ellipse	Included Bins	Center Point		Major Axis	Minor Axis	Rotation Angle (°)
			x	y	a	b	
2700 K	3-step	8G0	0.4578	0.4101	0.0081	0.0042	53.7
	5-step	8G0, 8E1, 8E2, 8E3, 8E4, 8E5, 8E6	0.4578	0.4101	0.0135	0.0070	53.7

KITTING

CHROMATICITY

CCT	Kitting	Included Bins
6500 K	3-step only	1G0
	N Kitting	1G0, 1E1, 1E2, 1E3, 1E4, 1E5, 1E6
5700 K	3-step only	2G0
	N Kitting	2G0, 2E1, 2E2, 2E3, 2E4, 2E5, 2E6
5000 K	3-step only	3G0
	N Kitting	3G0, 3E1, 3E2, 3E3, 3E4, 3E5, 3E6
4000 K	3-step only	5G0
	N Kitting	5G0, 5E1, 5E2, 5E3, 5E4, 5E5, 5E6
3500 K	3-step only	6G0
	N Kitting	6G0, 6E1, 6E2, 6E3, 6E4, 6E5, 6E6
3000 K	3-step only	7G0
	N Kitting	7G0, 7E1, 7E2, 7E3, 7E4, 7E5, 7E6
2700 K	3-step only	8G0
	N Kitting	8G0, E1, 8E2, 8E3, 8E4, 8E5, 8E6

N KITTING BIN DETAILS

1. Forward voltage bins are kitted in pairs of the same forward voltage bin.
2. Chromaticity bins are kitted as shown below in the following kitting examples.

Chromaticity Bins

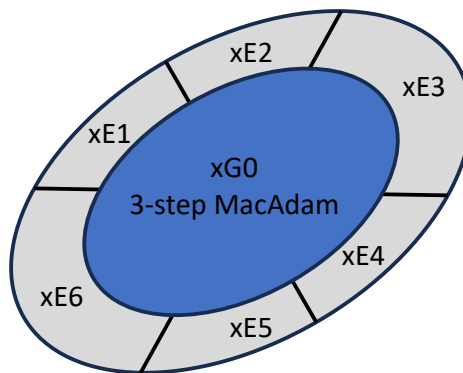

Kitted Bins

Item	Bin #1	Bin #2
Chromaticity Bin	xG0	xG0
	xE1	xE4
	xE2	xE5
	xE3	xE6

REFLOW SOLDERING CHARACTERISTICS

In testing, Cree Venture has found J Series 3030S Pro9 LEDs to be compatible with JEDEC J-STD-020C, using the parameters listed below. As a general guideline, Cree Venture recommends that users follow the recommended soldering profile provided by the manufacturer of the solder paste used, and therefore it is the lamp or luminaire manufacturer’s responsibility to determine applicable soldering requirements.

Note that this general guideline may not apply to all PCB designs and configurations of reflow soldering equipment.

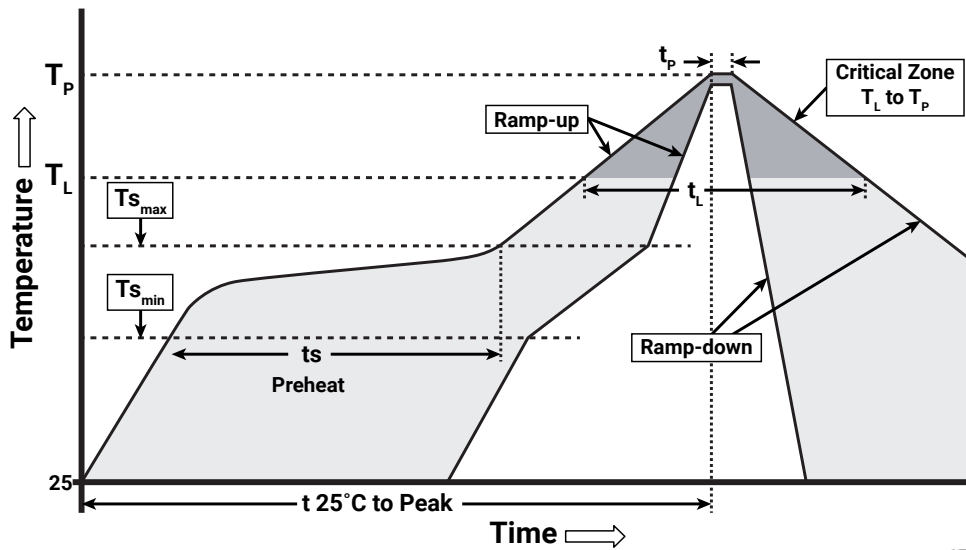

IPC/JEDEC J-STD-020C

Profile Feature	Lead-Free Solder
Temperature Min. ($T_{s_{min}}$)	150 °C
Temperature Max. ($T_{s_{max}}$)	200 °C
Time (t_s) from $T_{s_{min}}$ to $T_{s_{max}}$	60-120 seconds
Ramp-Up Rate (T_L to T_p)	3 °C/second
Liquidus Temperature (T_L)	217 °C
Time (t_L) Maintained Above T_L	60-150 seconds
Peak Package Body Temperature (T_p)	260 °C max.
Time (t_p) Within 5 °C of the Specified Classification Temperature (T_c)	30 seconds max.
Ramp-Down Rate (T_p to T_L)	6 °C/second max.
Time 25 °C to Peak Temperature	8 minutes max.

Note: All temperatures refer to the topside of the package, measured on the package body surface.

NOTES

LED Use

Use of this LED in information displays utilizing LCD Backlights and other emissive pixel display technology is prohibited (“Use Restrictions”).

Measurements

The luminous flux, radiant power, chromaticity, forward voltage and CRI measurements in this document are binning specifications only and solely represent product measurements as of the date of shipment. These measurements will change over time based on a number of factors that are not within Cree Venture’s control and are not intended or provided as operational specifications for the products. Calculated values are provided for informational purposes only and are not intended or provided as specifications.

Pre-Release Qualification Testing

Please read the [J Series Reliability Overview](#) for the details of the pre-release qualification testing for J Series LEDs.

Lumen Maintenance

Cree Venture uses standardized IES LM-80-08 and TM-21-11 methods for collecting long-term data and extrapolating LED lumen maintenance. For information on the specific LM-80 data sets available for this LED, refer to the public [J Series LM-80 results document](#).

Please read the [Thermal Management application note](#) for details on how thermal design, ambient temperature, and drive current affect the LED junction temperature.

Power Cycling

Switching cycles should not exceed the maximum number as shown in the following table.

Operating Temperature Range (Tsp)	Maximum Cycles
Below -10 °C	5,000

Moisture Sensitivity

Cree Venture recommends keeping J Series 3030S Pro9 LEDs in the provided, resealable moisture-barrier packaging (MBP) until immediately prior to soldering. Unopened MBP that contains J Series 3030S Pro9 LEDs does not need special storage for moisture sensitivity.

Once the MBP is opened, J Series 3030S Pro9 LEDs should be handled and stored as MSL 2A per JEDEC J-STD-033, meaning they have limited exposure time before damage to the LED may occur during the soldering operation. The table on the right specifies the maximum exposure time in days depending on temperature and humidity conditions. LEDs with exposure time longer than the specified maximums must be baked according to the baking conditions listed below.

Moisture Sensitivity Level	Temp.	Maximum Percent Relative Humidity				
		50%	60%	70%	80%	90%
Level 2A	30 °C	∞	28	1	1	1
Level 2A	25 °C	∞	∞	2	1	1
Level 2A	20 °C	∞	∞	2	2	1

NOTES - CONTINUED

Baking Conditions

It is not necessary to bake all J Series 3030S Pro9 LEDs. Only the LEDs that meet all of the following criteria must be baked:

1. LEDs that have been removed from the original MBP.
2. LEDs that have been exposed to a humid environment longer than listed in the Moisture Sensitivity section above.
3. LEDs that have not been soldered.

LEDs should be baked at 60 °C for 24 hours. LEDs may be baked in the original reels. Remove LEDs from the MBP before baking. Do not bake parts at temperatures higher than 60 °C. This baking operation resets the exposure time as defined in the Moisture Sensitivity section above.

RoHS Compliance

The levels of RoHS restricted materials in this product are below the maximum concentration values (also referred to as the threshold limits) permitted for such substances, or are used in an exempted application, in accordance with EU Directive 2011/65/EC (RoHS2), as implemented January 2, 2013. RoHS Declarations for this product can be obtained from your Cree Venture representative or from the [Product Ecology](#) section of the Cree LED website.

REACH Compliance

REACH substances of very high concern (SVHCs) information is available for this product. Since the European Chemical Agency (ECHA) has published notice of their intent to frequently revise the SVHC listing for the foreseeable future, please contact a Cree LED representative to insure you get the most up-to-date REACH SVHC Declaration. REACH banned substance information (REACH Article 67) is also available upon request.

Vision Advisory

WARNING: Do not look at an exposed lamp in operation. Eye injury can result. For more information about LEDs and eye safety, please refer to the [J Series LED Eye Safety application note](#).

MECHANICAL DIMENSIONS

All measurements are ± 0.2 mm unless otherwise indicated.

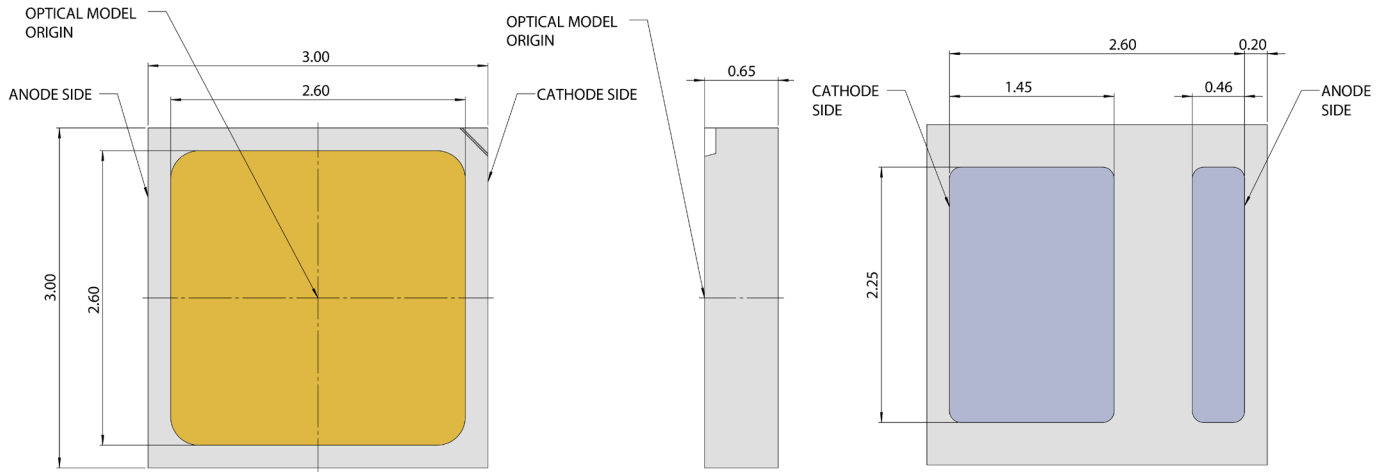

Top View

Side View

Bottom View

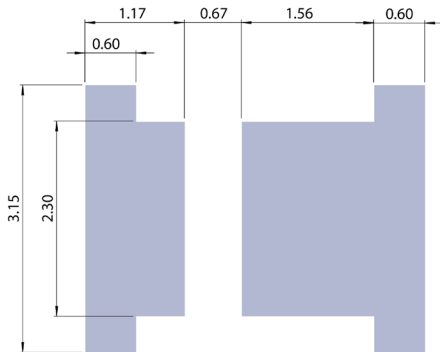

Recommended PCB Footprint

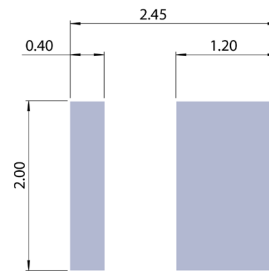

Recommended Stencil Opening

TAPE & REEL

All Cree Venture carrier tapes conform to EIA-481D, Automated Component Handling Systems Standard.

All dimensions in mm.

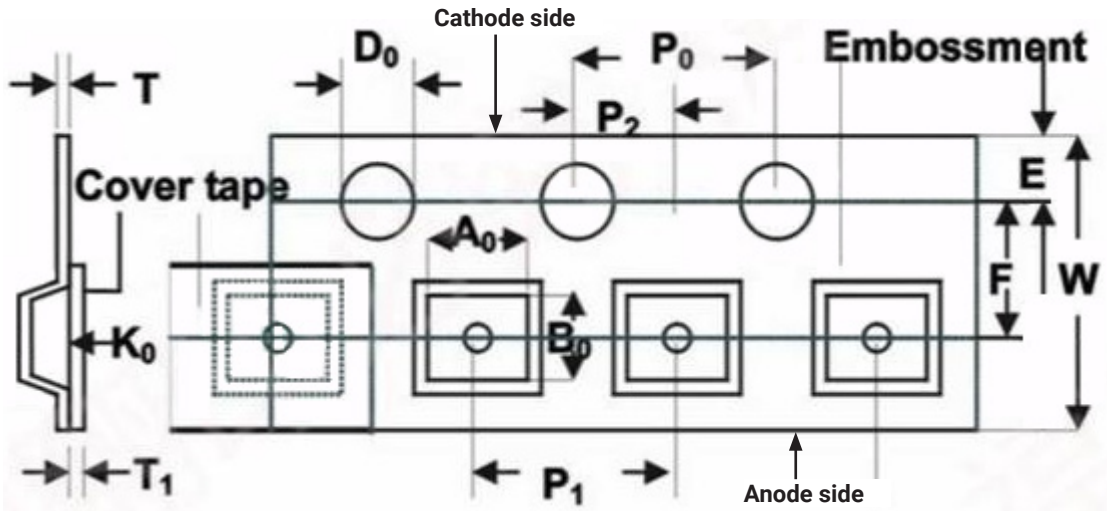

Symbol	Specification	Symbol	Specification
W	8.00 ± 0.30	A ₀	3.15 ± 0.10
E	1.75 ± 0.10	B ₀	3.15 ± 0.10
F	3.50 ± 0.05	K ₀	0.75 ± 0.10
D ₀	1.55 ± 0.10		
P ₀	4.00 ± 0.10		
P ₁	4.00 ± 0.10		
P ₂	2.00 ± 0.05		
T	0.20 ± 0.05		
T1	0.05 ± 0.01		

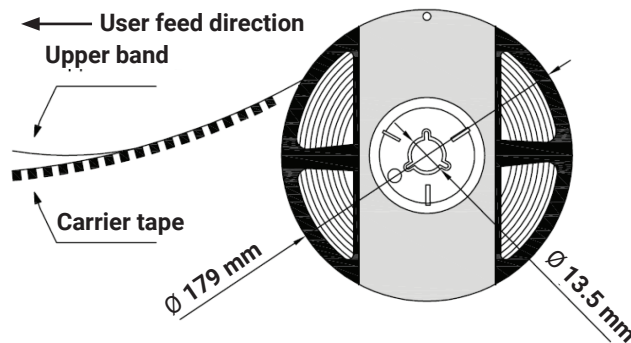
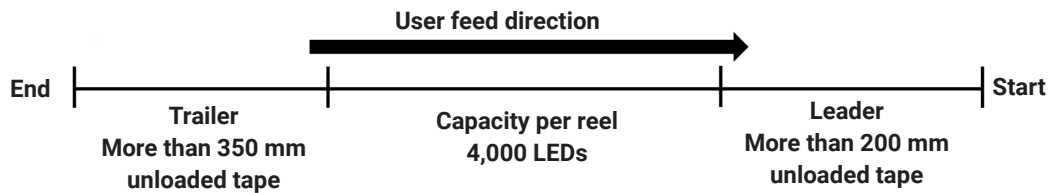

PACKAGING

Unpackaged Reel

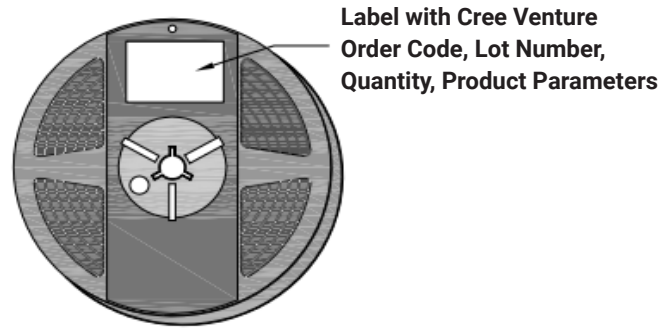

Packaged Reel

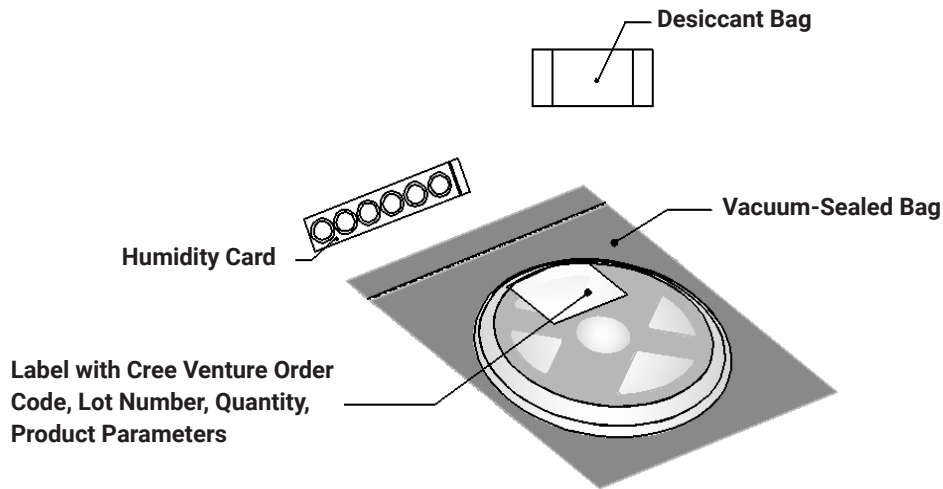

PACKAGING - CONTINUED

J Series 3030S Pro9 LEDs are packaged in boxes for shipment. Box sizes and the number of reels per box are as follows.

Box	Box Dimensions	Maximum Number of Reels per Box
1	250 x 210 x 30 mm	2
2	250 x 210 x 50 mm	4
3	530 x 230 x 275 mm	44
4	530 x 443 x 275 mm	88

Each box has at least one label (shown as a white square in the diagrams below) showing the order code, lot number, quantity, and product parameters.

Box 1

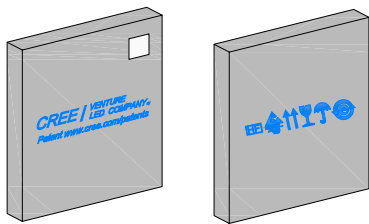

Box 2

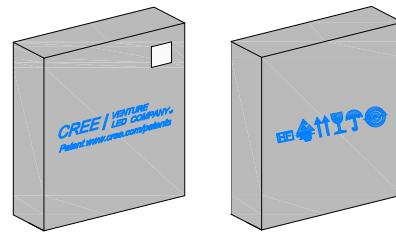

Box 3

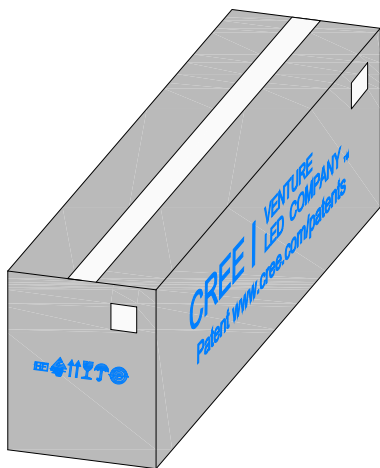

Box 4

